

The air-air pressure multiplier, or booster, is an automatic device that compresses air to give an outlet pressure that is double the inlet pressure.

It is normally used to locally intensify the input pressure of one or more actuators. As it is entirely pneumatic it can be used when electric devices are not recommended. The booster can be supplied with or without a pressure regulator.

It is fitted with check valves that maintain the outlet pressure even when the supply of compressed air is switched off. This means it is necessary to interrupt the supply and relieve the circuit before intervening on the device in any way. It is advisable to install a tank after the booster to prevent fluctuations in outlet pressure.



|                       | Art. No. B-921<br>Ident No. 101529  | Art. No. B-922<br>Ident No. 101531                               | Art. No. B-923<br>Ident No. 101530 | Art. No. B-924<br>Ident No. 101532                               |
|-----------------------|---|--|------------------------------------|--|
| <b>TECHNICAL DATA</b> | Booster Ø40   | Booster Ø40 with regulator                                       | Booster Ø63                        | Booster Ø63 with regulator                                       |
| Bore                  | ø 40  |  | ø 63                               |  |
| Fluid                 | Filtered unlubricated compressed air, Lubrication, if used, must be continuous. |  |                                    |  |
| Threaded port         | G 1/8   |  | G 3/8                              |  |
| Inlet pressure        | 0,2 ÷ 1<br>2 ÷ 10<br>29 ÷ 145   |  |                                    |  |
| Outlet pressure       | max 2<br>max 20<br>max 290  | max 1.6 (regulated)<br>max 16 (regulated)<br>max 232 (regulated) | max 2<br>max 20<br>max 290         | max 1.6 (regulated)<br>max 16 (regulated)<br>max 232 (regulated) |
| Operating temperature | -10° ÷ +60°<br>14° ÷ 140°   | -10° ÷ +50°<br>14° ÷ 122°  | -10° ÷ +60°<br>14° ÷ 140°          |  |
| Weight                | 1.380   | 1.600  | 4.240                              | 5.350  |
| Mounting              | Wall or panel   |  |                                    |  |
| Installation          | In any position   |  |                                    |  |

## OPERATING LAYOUT

The pressure booster is comprised of a central body (with one 3-2 valve, one 5-2 valve and four check valves), two side liners and a through rod on which two pistons are mounted.

The supply air is compressed alternately by the two pistons in one of the two central chambers (B and C); the other central chamber and one of the two side chambers (A and D) operate the pistons; the external chamber, which is not involved in compression, is relieved.

Air compressed at a ratio of 2:1 passes through a check valve that maintains the output pressure even when compressed air is no longer supplied.

The valves in the central body, which are operated by mechanical pusher pistons, switch the function of the two pairs of chambers (A and D, B and C) at each piston stroke.

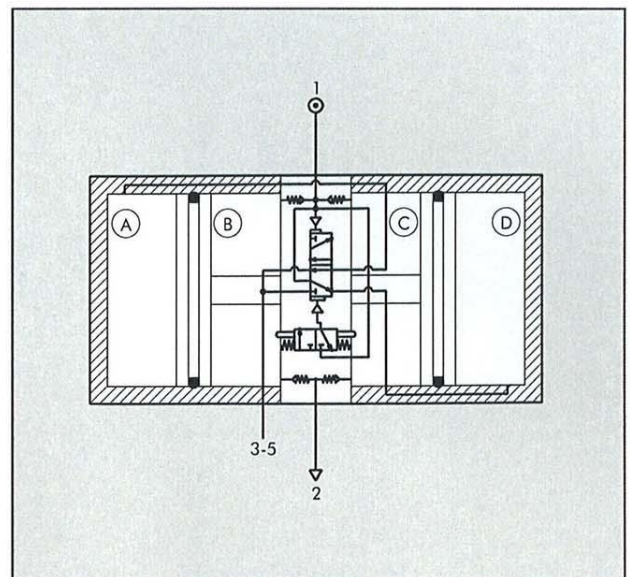

## COMPONENTS

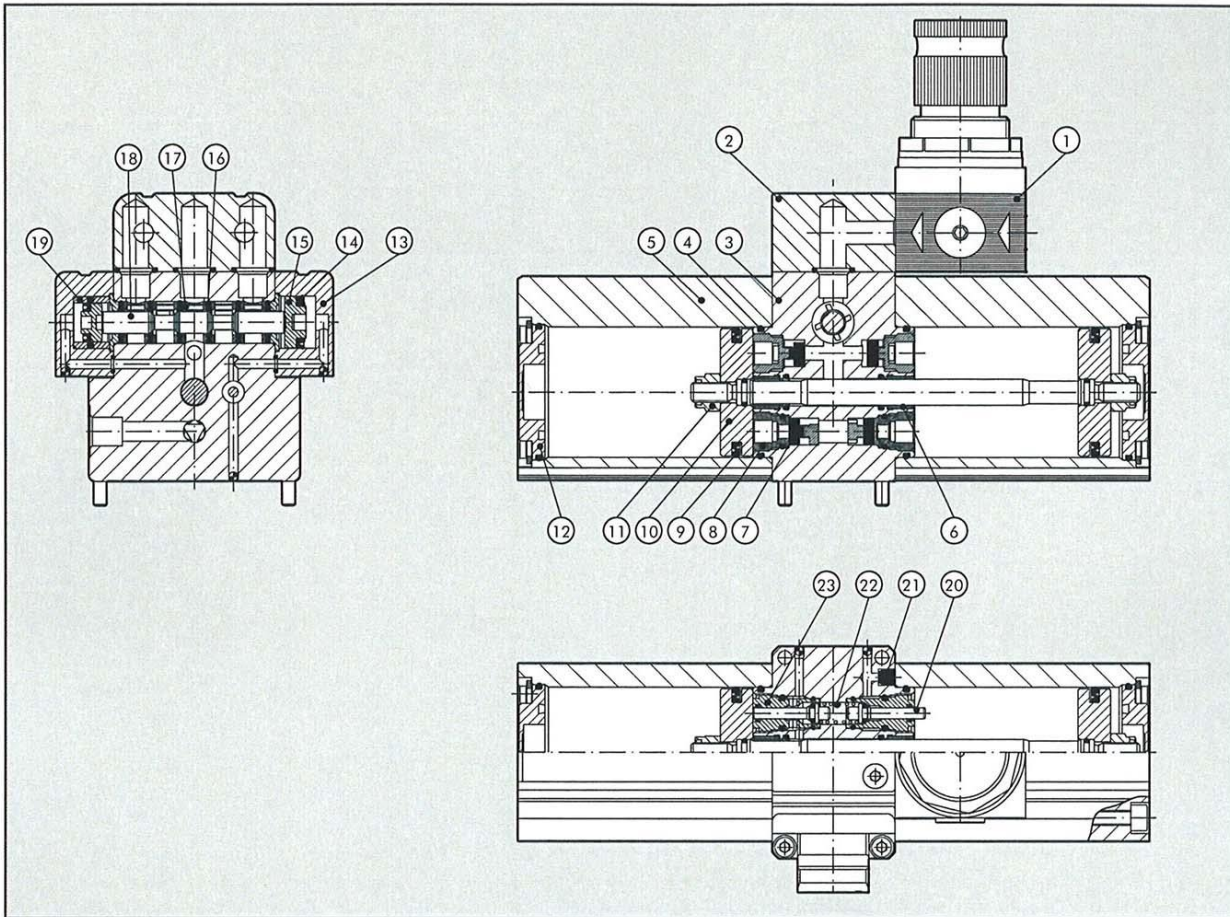

- |   |                                     |
|---|-------------------------------------|
| ① PRESSURE REGULATOR (for B-922, B-924 only)                    | ⑫ CYLINDER BASE: anodized aluminium |
| ② INTERFACE BLOCK (for B-922, B-924 only)<br>anodized aluminium | ⑬ VALVE CONTROL: anodized aluminium |
| ③ CENTRAL BODY: anodized aluminium                              | ⑭ VALVE CONTROL GASKET: NBR rubber  |
| ④ OR SEAL: NBR rubber   | ⑮ VALVE PISTON: technopolymer       |
| ⑤ BARREL: anodized aluminium alloy section                      | ⑯ GASKET: NBR rubber                |
| ⑥ GUIDE BUSHING: steel strip with bronze and PTFE insert        | ⑰ SPACER: technopolymer             |
| ⑦ POPPET: NBR rubber  | ⑱ SPOOL: nickel-plated aluminium    |
| ⑧ CHECK VALVE: brass  | ⑲ DIFFERENTIAL BUSHING: brass       |
| ⑨ PISTON GASKET: NBR rubber                                     | ⑳ PUSHER: stainless steel           |
| ⑩ PISTON: aluminium   | ㉑ SILENCER: technopolymer           |
| ⑪ SELF-LOCKING NUT: stainless steel                             | ㉒ SPRING: stainless steel           |
|   | ㉓ GUIDE BUSHING: brass              |

## MOUNTING

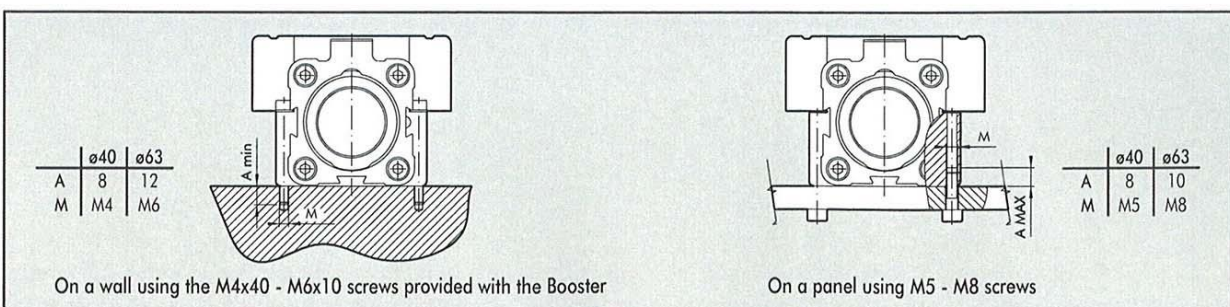

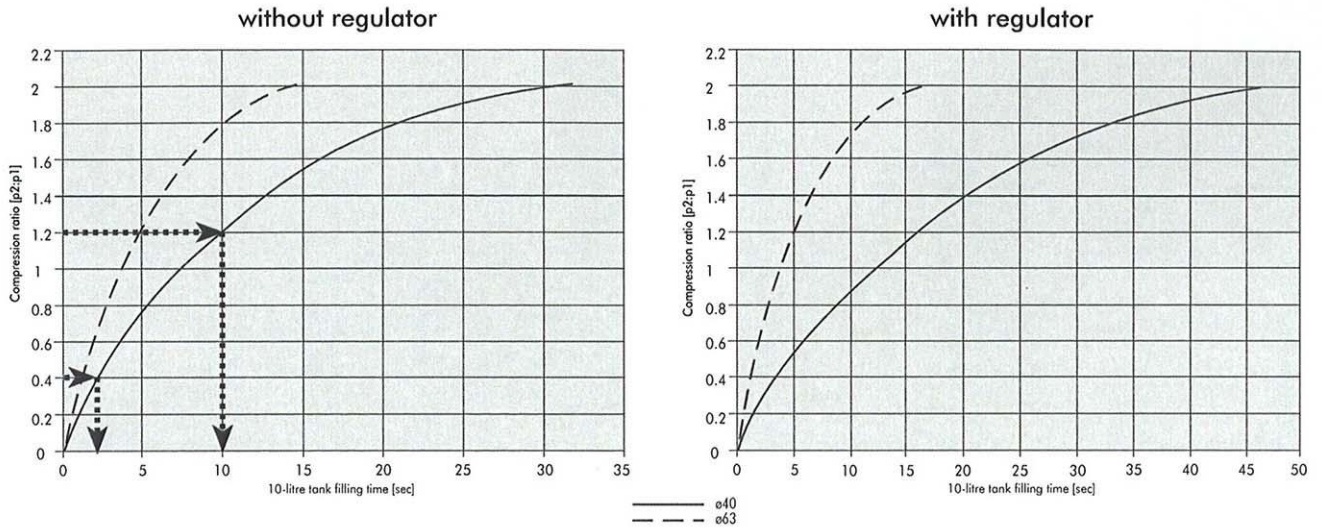
**TANK FILLING CURVES**

The graphs refer to the filling of a 10-litre tank and show the ratio of outlet to inlet pressure (=  $p_2:p_1$ ) as a function of time (sec). The graphs are valid for any inlet pressure between 2 and 10 bar. The following formula can be used to calculate the time  $t$  (sec) required to switch from pressure ratio 1 to pressure ratio 2 in a tank of volume  $V$  (litres):

$$t = \frac{V (t_2 - t_1)}{10}$$

where  $t_1$  and  $t_2$  are the times shown on the x-axis, corresponding to ratios 1 and 2.

E.g.

$$1 = 0.4 \Rightarrow t_1 = 2.5 \text{ sec}$$

$$2 = 1.2 \Rightarrow t_2 = 10 \text{ sec}$$

The time required to switch from 1 to 2 with a 25-litre tank is:

$$t = \frac{25 (10 - 2.5)}{10} \text{ sec} = 18.75 \text{ sec}$$

## FLOW CHARTS

without regulator Ø40

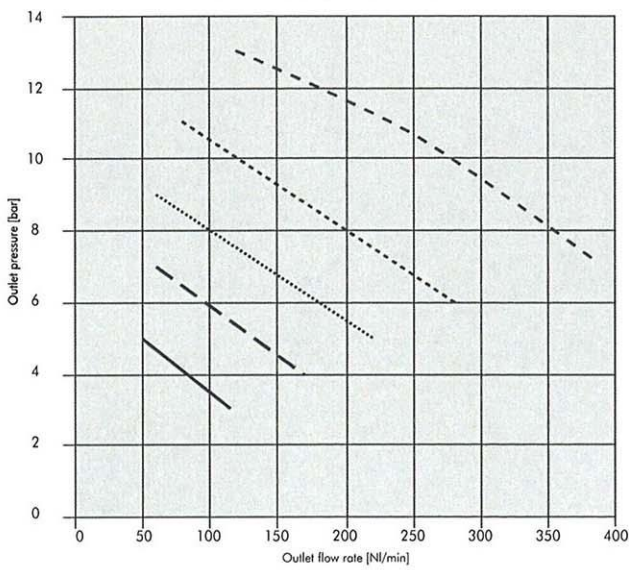

with regulator Ø40

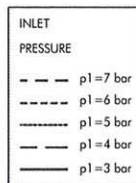
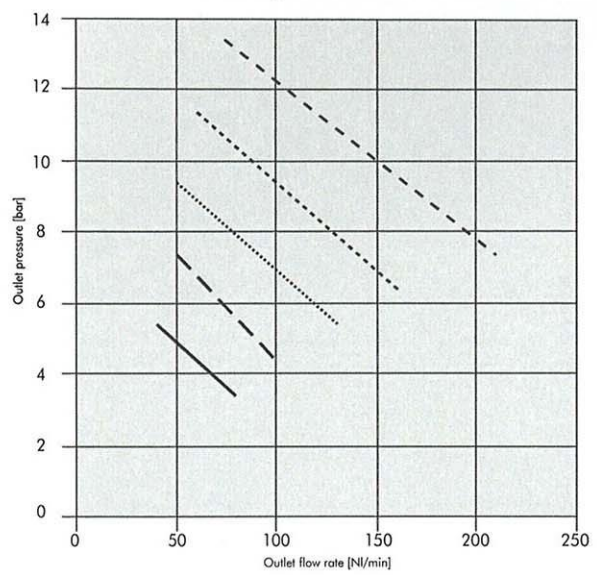

without regulator Ø63

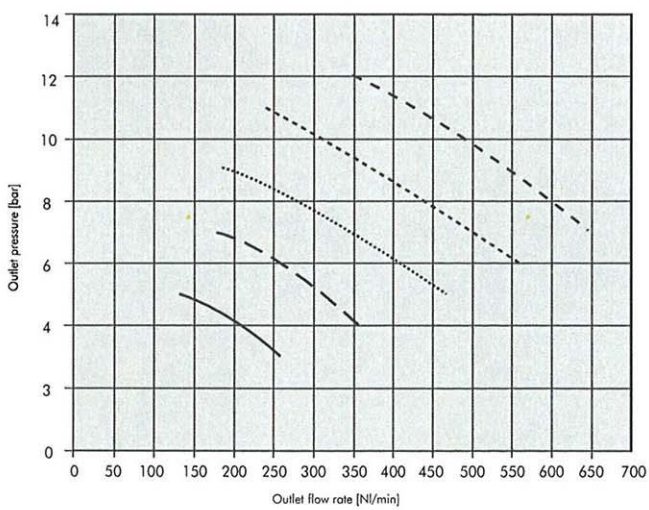

with regulator Ø63

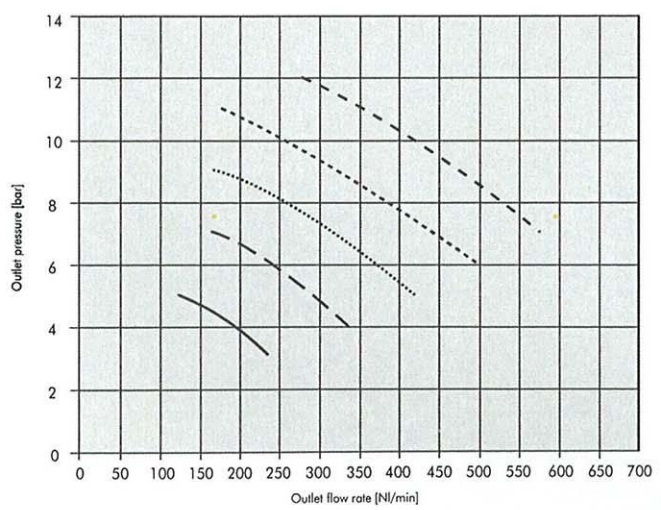

**PRESSURE MULTIPLIER (Booster  $\varnothing$  40 - 63)**

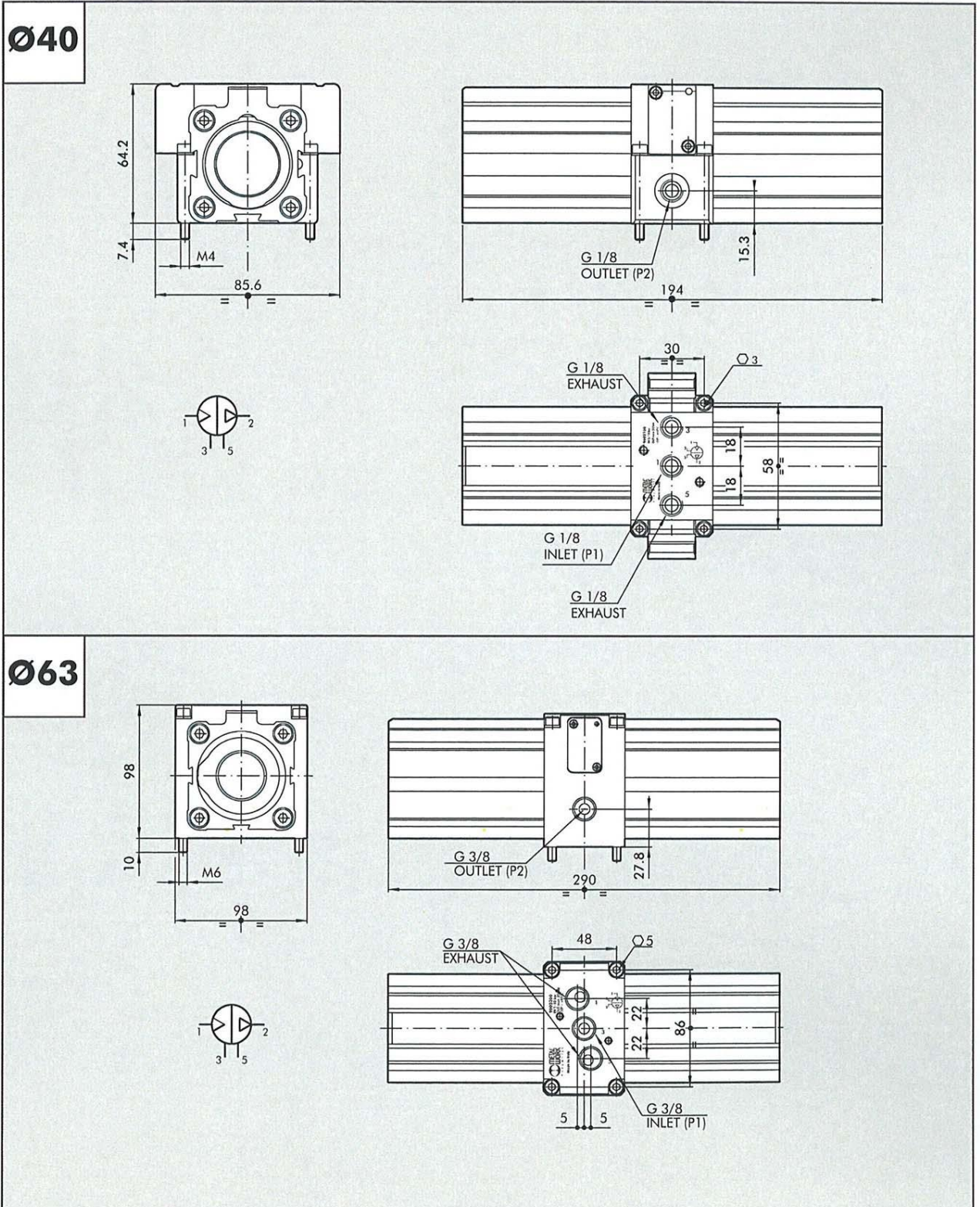

# Double piston pressure multiplier (booster)

Type No. B-921 to B-924



## PRESSURE MULTIPLIER (ø 40 - 63 Booster with regulator)

**Ø40**

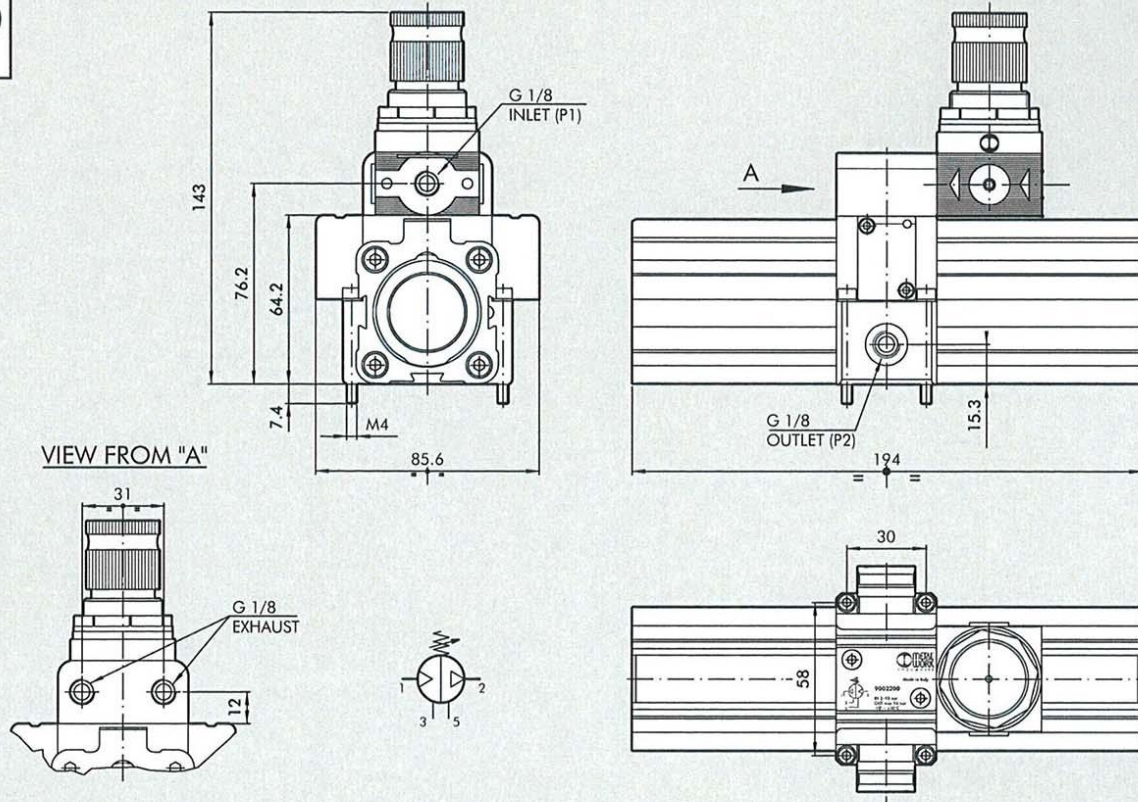

**Ø63**

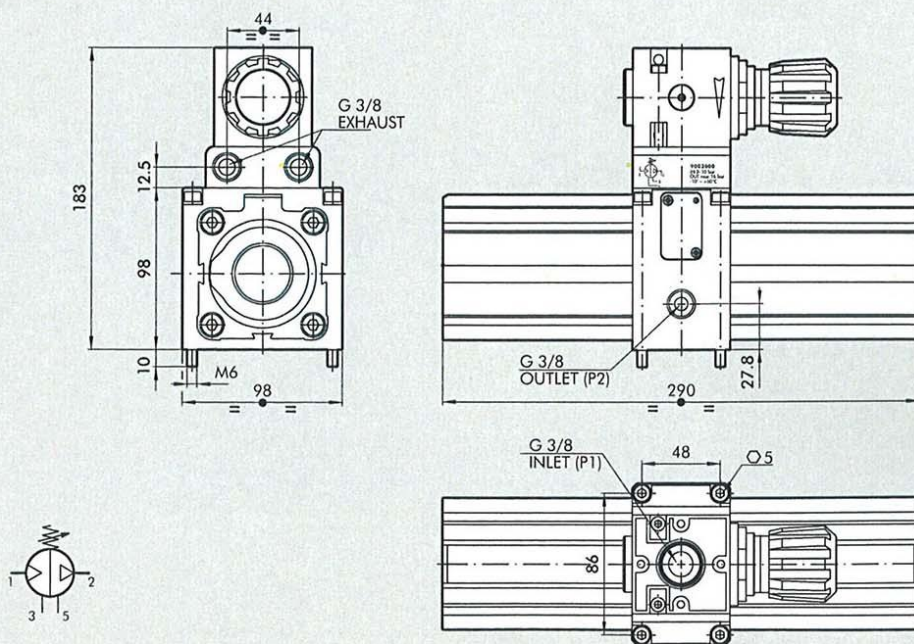

**ø 40 REGULATOR UNIT**

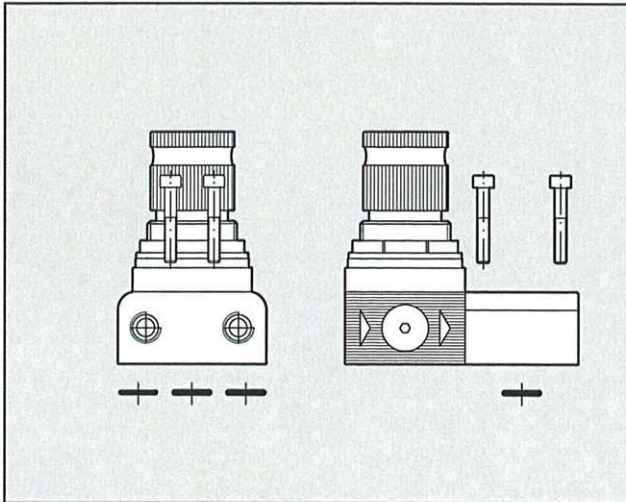

| Code  | Description        |
|-------|--------------------|
| B-930 | ø40 Regulator unit |

Note: Supplied with 2 screws, 3 O-ring

**ø 63 REGULATOR UNIT**

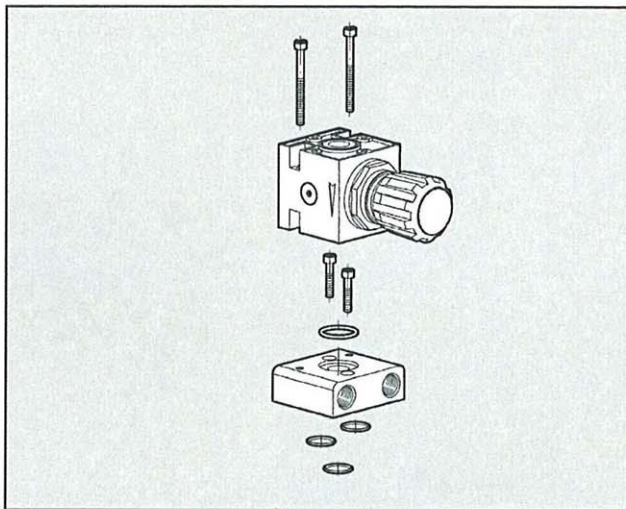

| Code  | Description        |
|-------|--------------------|
| B-931 | ø63 Regulator unit |

Nota: fornito completo di N. 4 viti, N. 4 O-ring

SET OF GASKETS

